

FEDERAL SUPPLY CLASS
4730

REV.
F

AS5174™

RATIONALE

NEW HEAT TREATMENT NOTE 2b ADDED. FINISH NOTES 3.b.2 AND 3.h.2 REVISED. QML STATEMENT REVISED. "INTENDED USE" NOTE REVISED. TABLE 2 REMOVED. "INACTIVE" STATUS REPLACED BY "NOT RECOMMENDED." USE OF TITANIUM IN OXYGEN SYSTEM WARNING NOTE REMOVED. NATO STANAG AGREEMENT NOTE 20 REMOVED. NEW NOTE 22 ADDED.

SAE Technical Standards Board Rules provide that: "This report is published by SAE to advance the state of technical and engineering sciences. The use of this report is entirely voluntary, and its applicability and suitability for any particular use, including any patent infringement arising therefrom, is the sole responsibility of the user." SAE reviews each technical report at least every five years at which time it may be revised, reaffirmed, stabilized, or cancelled. SAE invites your written comments and suggestions.

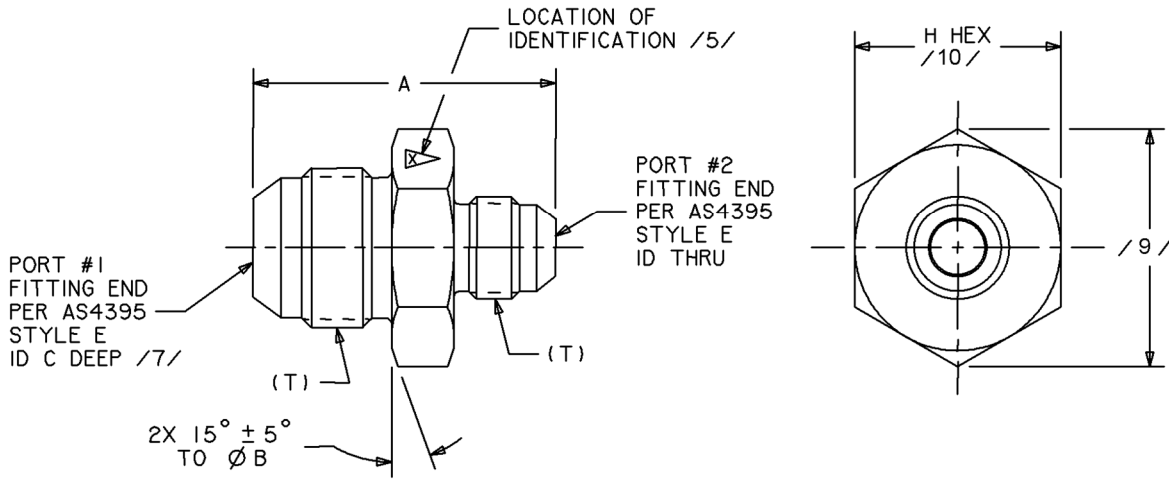
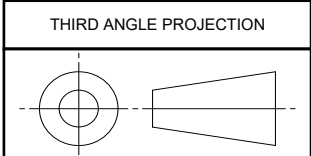

FIGURE 1 - FITTING, UNION AND REDUCER

NOT RECOMMENDED IN PART /21/

For more information on this standard, visit
<https://www.sae.org/standards/content/AS5174F>



CUSTODIAN: G-3/G-3B

PROCUREMENT SPECIFICATION: AS4841 /4/



AEROSPACE STANDARD

FITTING, UNION AND REDUCER, FLARED

AS5174™
SHEET 1 OF 7

REV.
F

ISSUED 1998-03 REAFFIRMED 2015-04 REVISED 2020-05

TABLE 1B - DIMENSION C

PORT #1 /19/ SIZE CODE	C±.031 PORT #2 SIZE CODE	C±.031 PORT #2 SIZE CODE	C±.031 PORT #2 SIZE CODE	C±.031 PORT #2 SIZE CODE	C±.031 PORT #2 SIZE CODE	C±.031 PORT #2 SIZE CODE	C±.031 PORT #2 SIZE CODE	C±.031 PORT #2 SIZE CODE	C±.031 PORT #2 SIZE CODE	C±.031 PORT #2 SIZE CODE	C±.031 PORT #2 SIZE CODE	C±.031 PORT #2 SIZE CODE	C±.031 PORT #2 SIZE CODE	C±.031 PORT #2 SIZE CODE	C±.031 PORT #2 SIZE CODE	C±.031 PORT #2 SIZE CODE	C±.031 PORT #2 SIZE CODE	C±.031 PORT #2 SIZE CODE	C±.031 PORT #2 SIZE CODE						
02	03	04	05	06	08	10	12	16	20	24	28	32	40	48											
02	-	-	-	-	-	-	-	-	-	-	-	-	-	-	-	-	-	-	-	-					
03	.625	-	-	-	-	-	-	-	-	-	-	-	-	-	-	-	-	-	-	-	-				
04	.688	.578	-	-	-	-	-	-	-	-	-	-	-	-	-	-	-	-	-	-	-	-			
05	-	.609	-	-	-	-	-	-	-	-	-	-	-	-	-	-	-	-	-	-	-	-	-		
06	.625	.625	.625	-	-	-	-	-	-	-	-	-	-	-	-	-	-	-	-	-	-	-	-	-	
08	.719	.719	.719	.719	-	-	-	-	-	-	-	-	-	-	-	-	-	-	-	-	-	-	-	-	
10	-	.797	-	.797	.797	-	-	-	-	-	-	-	-	-	-	-	-	-	-	-	-	-	-	-	-
12	-	.891	.891	.891	.891	.891	-	-	-	-	-	-	-	-	-	-	-	-	-	-	-	-	-	-	-
16	-	.891	-	-	.891	.891	.891	-	-	-	-	-	-	-	-	-	-	-	-	-	-	-	-	-	-
20	-	.859	-	-	-	-	.859	.859	-	-	-	-	-	-	-	-	-	-	-	-	-	-	-	-	-
24	-	-	-	-	-	-	-	.906	.906	-	-	-	-	-	-	-	-	-	-	-	-	-	-	-	-
28	-	-	-	-	-	-	-	-	-	-	-	-	-	-	-	-	-	-	-	-	-	-	-	-	-
32	-	-	-	-	-	-	-	-	-	-	-	-	-	-	-	-	-	-	-	-	-	-	-	-	-
40	-	-	-	-	-	-	-	-	-	-	-	-	-	-	-	-	-	-	-	-	-	-	-	-	-
48	-	-	-	-	-	-	-	-	-	-	-	-	-	-	-	-	-	-	-	-	-	-	-	-	-